

AMCELL*Jet*[®]

METAL BINDER JETTING EVOLUTION

Piezoelectric Printhead
50 µm Layer Thickness
120 x 200 x 75 mm
Build Volume

Integrated with **EVAM SOFTWARE**



TRIDITIVE
ADDITIVE MANUFACTURING

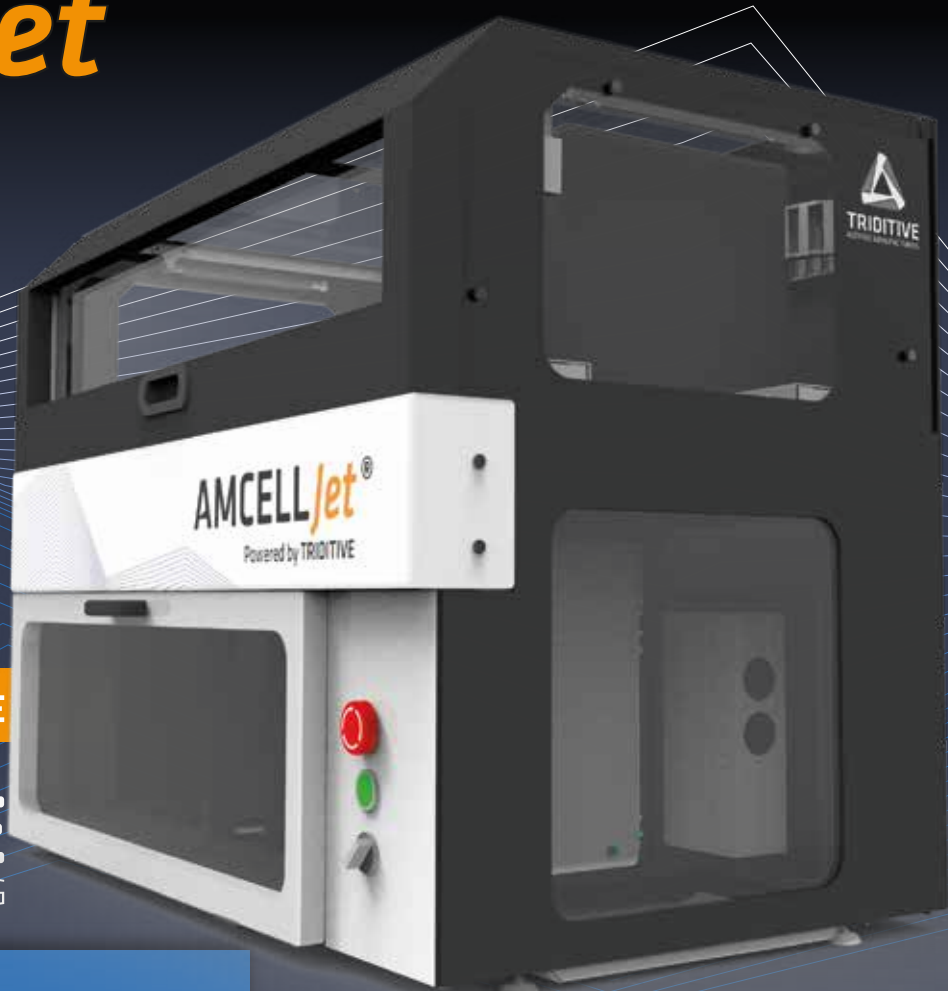

More information at triditive.com

Technical Specification*

X/Y Resolution	600 dpi
Layer Thickness	50 µm
Printing Volume	216 mm x 140 mm x 80 mm
Max. Printing Throughput	1000 cc/hr - 61in ³
External Dimensions	900mm x 500mm x 700mm
Powder Supply System	Box to box supply system
Powder Tray	Single powder Tray
Printhead	2x Piezoelectric printheads
Weight	~100Kg
Temperature Range	20 ~ 25°C
Humidity Range	40 ~ 60%
Model Tray	Removable

Powder Spreading	Up to 10 ips
	Up to 750 rpm
	Spreading Roller Diameter: 30mm

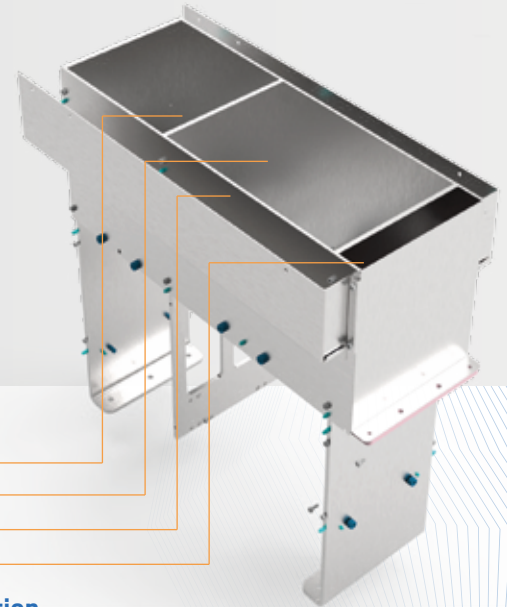

Powder Tray

Model Tray

Overflow (Side)

Overflow



WATER BASED AMCELL JET® BINDER WB-01

Water Based Binder
Friendly Handling
Cost efficient

Contact information

info@triditive.com | sales@triditive.com | +34 984 200 010